

# Akamai Global Traffic Management

## *Maximize revenues and improve loyalty by ensuring customer facing webpages have optimal responsiveness and availability*

The challenges companies face to maintain a global web presence continues to escalate. To achieve customer loyalty and maximize revenues, Web site administrators must aim for zero-downtime while also providing optimal response times to their Web site.

Achieving high availability and optimal response times on a global basis often involves a variety of implementation strategies including, but not limited to, geographically diverse datacenters and redundant architectures and components. If possible, Web site availability and server utilization should be continuously monitored at the datacenter level, along with the end user's ability to actually reach the datacenter from the Internet. Traditional hardware load balancing appliances do not factor in Internet bottlenecks such as over-congestion, inefficient BGP routing decisions, nor ISP peering points - which can effect an end user's ability to be connected to an appropriate datacenter.

Akamai's Global Traffic Management service applies an Internet-centric approach to global server load balancing to ensure high availability and responsiveness to user requests. Unlike traditional hardware-based solutions that reside within the datacenter, Akamai's Global Traffic Management service is a fault tolerant system that makes intelligent routing decisions based on real-time server and Internet conditions to ensure user requests can reach the datacenter.

Customers can select from four service variants of Global Traffic Management:

**Failover**—directs requests to an alternate location when there is a failure at a primary site. The Failover solution can be used across disparate network carriers.

**IP Intelligence**—directs requests to a closest datacenter based on geographic or IP rules.

**Performance**—requests are directed as determined through multivariate policy rules featuring percentage-based load balancing and load feedback to allow for server specific load balancing within a datacenter.

**Performance Plus**—enhances the Performance version by deploying Akamai network agents at each point of origin to enable a datacenter-to-Internet viewpoint allowing for more precise decisions when directing end user requests.

## How Akamai's Global Traffic Management Works

Akamai monitors Web site availability through widely-deployed points-of-presence to capture Internet traffic conditions relative to the customer's datacenters. Based on these conditions, customer-specific policy rules are evaluated against real-time Internet traffic conditions. When a user tries to access a Web site, the user is first directed first to one of Akamai's geographically-dispersed name servers, which execute the customer's policy rules using a patent pending path optimization algorithm to determine which datacenter location is optimal for the user.

The Global Traffic Management service can easily integrate with a customer's Web infrastructure. Akamai's Global Traffic Management is a DNS-based load sharing solution whereby the Web site's authoritative name server is given a CNAME; as a result, Akamai name servers respond to the end user's local name server with the proper routing, based on the policy rules established by the customer.

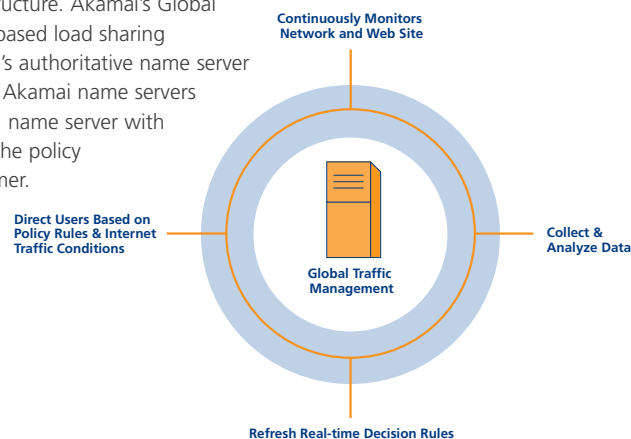

## Benefits To Your Business

### Improved Availability

Looks at traffic management with an Internet centric view to ensure users can reach your Web site, as opposed to simply evaluating if servers are functional.

### Improved Response Time

Real-time Internet conditions, such as latency and packet loss, are used to determine an optimal path, as opposed to arbitrary measures such as number of hops or a weighted round robin traffic distribution. By factoring real-time Internet conditions into policy decisions, Akamai can mitigate the impact of Internet congestion.

### Lower Cost of Ownership

Managed service approach enables global growth without exponentially growing IT infrastructure OPEX and CAPEX associated with hardware-based approaches.

### Network Visibility and Control

Allows administrators to dynamically modify traffic allocation and set-up new properties. Visibility to real-time data, summarized reports and alerts provide administrators the means to identify and address potential problems.

### Built-in Reliability and Redundancy

Geographic and network diverse infrastructure components ensure high service availability and survivability from potential security threats - backed by a world-class SLA.

### Proven Solution

Leverage the same technology powering Akamai's global distribution network and the world's busiest Web properties.

*continued on back*

## How Akamai's Global Traffic Management Works *continued*

From an end user's perspective, the Global Traffic Management service works as follows:

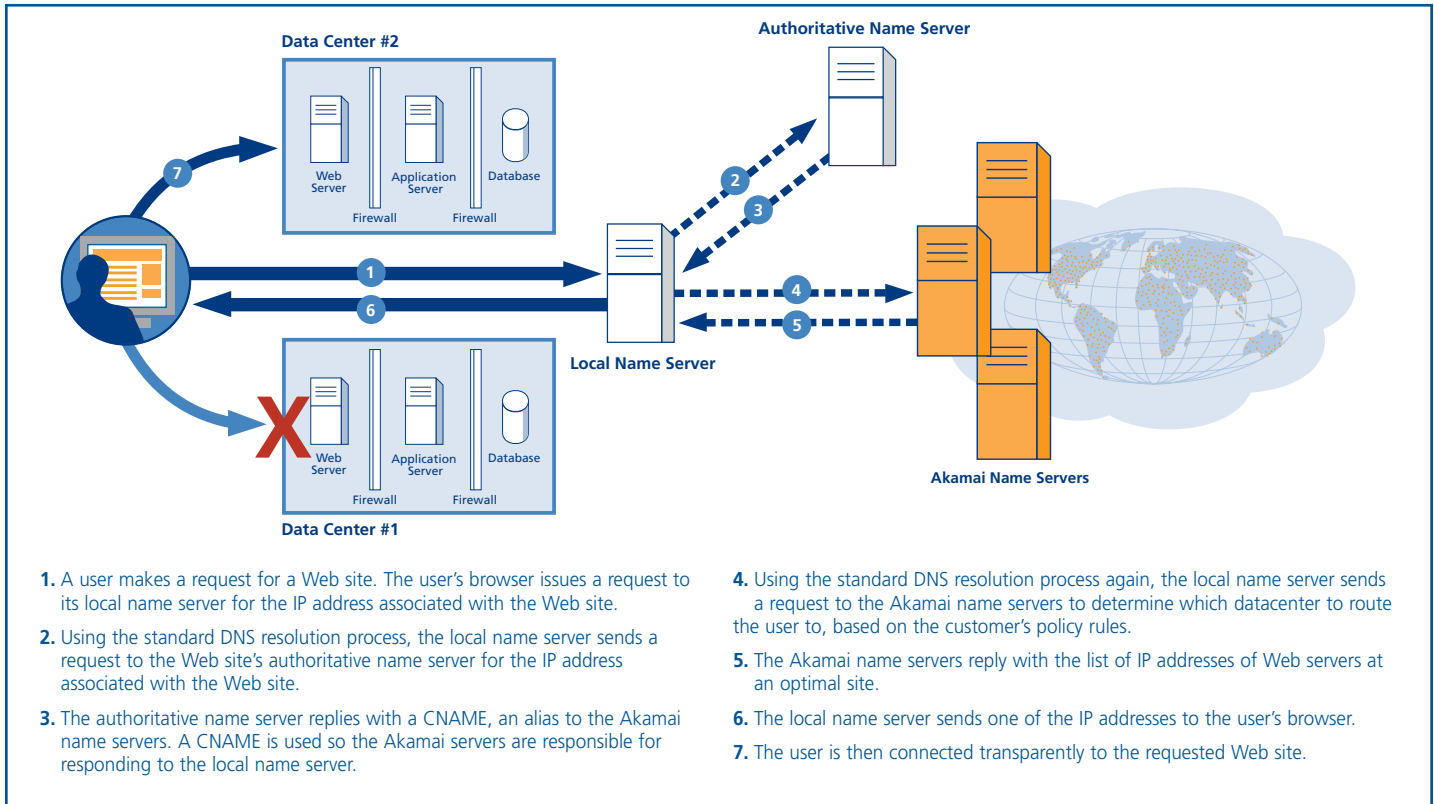

Global Traffic Management can be combined easily with other Akamai services to provide powerful and highly available Web delivery solutions. For example, when combined with Akamai's Dynamic Site Delivery service, user requests are first directed to an optimal Akamai edge server. As needed, the Akamai edge server then uses Global Traffic Management to select one of a set of origin servers to accelerate the delivery of dynamic content across the Akamai network to or from the origin server location chosen by the Global Traffic Management policy rules.

Global Traffic Manager is a trusted and proven solution used by many of the world's most heavily-trafficked Web sites. Simply knowing datacenter servers are functional is not enough when running a mission critical application. Akamai ensures that Internet users can actually get to the Web site. Backed by a 100% SLA, customers can be assured that Akamai will direct traffic to a live customer server all the time.

### About Akamai

Akamai is the leading global service for distributing online content and business processes. More than 1,900 organizations have formed trusted relationships with Akamai, improving revenue and reducing costs by maximizing their online business performance. Leveraging the Akamai EdgePlatform, these organizations gain business advantage today, while building a foundation for the emerging Web solutions of tomorrow. Akamai is "The Trusted Choice for Online Business." For more information, visit [www.akamai.com](http://www.akamai.com).



**Akamai Technologies, Inc.**  
 U.S. Headquarters  
 8 Cambridge Center, Cambridge, MA 02142  
 Tel 617.444.3000  
 Fax 617.444.3001  
 U.S. toll-free 877.4AKAMAI  
 (877.425.2624)

**Akamai Technologies, GmbH**  
 Park Village, Betastrasse 10 bD-85774  
 Unterföhring, Germany  
 Tel +49 89 94006-0  
[www.akamai.com](http://www.akamai.com)

© 2006 Akamai Technologies, Inc. All Rights Reserved. Reproduction in whole or in part in any form or medium without express written permission is prohibited. Akamai, the Akamai wave logo, EdgeSuite, and EdgeComputing are registered trademarks. Other trademarks contained herein are the property of their respective owners. Akamai believes that the information in this publication is accurate as of its publication date; such information is subject to change without notice.

AKAMS-GTM-0306